

INSTRUCTION MANUAL

EB-260A

Swivel Head Metal Cutting Band Saw (240V)
225 x 180mm (W x H) Rectangle



B062

PLANT SAFETY PROGRAM

NEW MACHINERY HAZARD IDENTIFICATION, ASSESSMENT & CONTROL

Metal Cutting Bandsaw

Developed in Co-operation Between A.W.I.S.A and Australia Chamber of Manufactures
This program is based upon the Australian Worksafe Standard for Plant(NOHSC:1010-1994)

Item No.	Hazard Identification	Hazard Assessment	Risk Control Strategies <small>(Recommended for Purchase / Buyer / User)</small>
A	ENTANGLEMENT	HIGH	Eliminate, avoid loose clothing / Long hair etc. Secure & support Long / heavy material
B	CRUSHING	LOW	
C	CUTTING, STABBING, PUNCTURING	MEDIUM	Blade guards should always be in the closed position before starting machine. Blade guide system should be adjusted to suit material width. Wear gloves when changing blades. Isolate main power switch before changing blade, cleaning or adjusting. If blade breaks do not open door until both wheels have stopped. Check blade tracking before starting.
D	SHEARING	MEDIUM	Make sure all guards are secured shut when machine is on. Isolate power to machine prior to changing belts or maintenance.
F	STRIKING	LOW	Support long heavy jobs and stand clear of offcuts. Stand clear of machine when in operation. Remove all loose objects around moving parts. Wear safety glasses
H	ELECTRICAL	MEDIUM	All electrical enclosures should only be opened with a tool that is not to be kept with the machine.
O	OTHER HAZARDS, NOISE.	LOW	Machine should be installed & checked by a Licensed Electrician. Wear hearing protection as required.
Plant Safety Program to be read in conjunction with manufactures instructions			



www.machineryhouse.com.au



www.machineryhouse.co.nz

Authorised and signed by:
Safety officer:
Manager:
.....

Revised Date: Aug-08



WARNING

General Machinery Safety Instructions

Machinery House
requires you to read this entire Manual before using this machine.

- 1. Read the entire Manual before starting machinery.** Machinery may cause serious injury if not correctly used.
- 2. Always use correct hearing protection when operating machinery.** Machinery noise may cause permanent hearing damage.
- 3. Machinery must never be used when tired, or under the influence of drugs or alcohol.** When running machinery you must be alert at all times.
- 4. Wear correct Clothing.** At all times remove all loose clothing, necklaces, rings, jewelry, etc. Long hair must be contained in a hair net. Non-slip protective footwear must be worn.
- 5. Always wear correct respirators around fumes or dust when operating machinery.** Machinery fumes & dust can cause serious respiratory illness. Dust extractors must be used where applicable.
- 6. Always wear correct safety glasses.** When machining you must use the correct eye protection to prevent injuring your eyes.
- 7. Keep work clean and make sure you have good lighting.** Cluttered and dark shadows may cause accidents.
- 8. Personnel must be properly trained or well supervised when operating machinery.** Make sure you have clear and safe understanding of the machine you are operating.
- 9. Keep children and visitors away.** Make sure children and visitors are at a safe distance for you work area.
- 10. Keep your workshop childproof.** Use padlocks, Turn off master power switches and remove start switch keys.
- 11. Never leave machine unattended.** Turn power off and wait till machine has come to a complete stop before leaving the machine unattended.
- 12. Make a safe working environment.** Do not use machine in a damp, wet area, or where flammable or noxious fumes may exist.
- 13. Disconnect main power before service machine.** Make sure power switch is in the off position before re-connecting.
- 14. Use correct amperage extension cords.** Undersized extension cords overheat and lose power. Replace extension cords if they become damaged.
- 15. Keep machine well maintained.** Keep blades sharp and clean for best and safest performance. Follow instructions when lubricating and changing accessories.
- 16. Keep machine well guarded.** Make sure guards on machine are in place and are all working correctly.
- 17. Do not overreach.** Keep proper footing and balance at all times.
- 18. Secure workpiece.** Use clamps or a vice to hold the workpiece where practical. Keeping the workpiece secure will free up your hand to operate the machine and will protect hand from injury.
- 19. Check machine over before operating.** Check machine for damaged parts, loose bolts, Keys and wrenches left on machine and any other conditions that may effect the machines operation. Repair and replace damaged parts.
- 20. Use recommended accessories.** Refer to instruction manual or ask correct service officer when using accessories. The use of improper accessories may cause the risk of injury.
- 21. Do not force machinery.** Work at the speed and capacity at which the machine or accessory was designed.
- 22. Use correct lifting practice.** Always use the correct lifting methods when using machinery. Incorrect lifting methods can cause serious injury.
- 23. Lock mobile bases.** Make sure any mobile bases are locked before using machine.
- 24. Allergic reactions.** Certain metal shavings and cutting fluids may cause an allergic reaction in people and animals, especially when cutting as the fumes can be inhaled. Make sure you know what type of metal and cutting fluid you will be exposed to and how to avoid contamination.
- 25. Call for help.** If at any time you experience difficulties, stop the machine and call you nearest branch service department for help.



Metal Cutting Bandsaw Safety Instructions

Machinery House
requires you to read this entire Manual before using this machine.

- 1. Maintenance.** Make sure the bandsaw is turned off and disconnect from the main power supply and make sure all moving parts have come to a complete stop before any inspection, adjustment or maintenance is carried out.
- 2. Bandsaw Condition.** Bandsaw must be maintained for a proper working condition. Never operate a bandsaw that has damaged or worn parts. Scheduled routine maintenance should be performed on a scheduled basis.
- 3. Blade Condition.** Never operate a bandsaw with a dull, cracked or badly worn blade. Before using a bandsaw inspect blades for missing teeth and cracks.
- 4. Replacing Blade.** Make sure teeth are facing the correct direction. Wear gloves to protect hands and wear safety glasses to protect your eyes.
- 5. Hand Hazard.** Keep hands and fingers clear from the line of cut of the blade and offcuts workpieces. Hands can be crushed in vice or from falling machine components and cut by the blade.
- 6. Leaving a bandsaw Unattended.** Always turn the bandsaw off and make sure all moving parts have come to a complete stop before leaving the bandsaw. Do not leave bandsaw running unattended for any reason.
- 7. Avoiding Entanglement.** Blade guard must be used at all times. Remove loose clothing, belts, or jewelry items. Never wear gloves while machine is in operation. Tie up long hair and use the correct hair nets to avoid any entanglement with the bandsaw moving parts.
- 8. Understand the machines controls.** Make sure you understand the use and operation of all controls.
- 9. Power outage.** In the event of a power failure during use of the bandsaw, turn off all switches to avoid possible sudden start up once power is restored.
- 10. Work area hazards.** Keep the area around the bandsaw clean from oil, tools, chips. Pay attention to other persons in the area and know what is going on around the area to ensure unintended accidents.
- 11. Workpiece Handling.** Workpieces must be supported with table, vice, roller conveyor/stands, or other support fixtures. Unsupported workpieces may cause the machine to tip over and fall. Flag long pieces of material to avoid tripping hazards. Never hold a workpiece with your hands during the cut process.
- 12. Hearing protection and hazards.** Always wear hearing protection as noise generated from bandsaw blade and workpiece vibration, material handling, and power transmission can cause permanent hearing loss over time.
- 13. Hot surfaces.** Workpieces, machine surfaces and chips become hot due to friction and can burn you.
- 14. Starting position.** Never turn the bandsaw on when the blade is resting on the workpiece.
- 15. Guards.** Do not operate bandsaw without the blade guard in place or with the doors open.
- 16. Call for help.** If at any time you experience difficulties, stop the machine and call your nearest branch service department for help.

SAFETY RULES

WARNING: When using electric tools basic safety precautions should always be followed to reduce the risk of fire, electric shock and personal injury!

As with all machinery there are certain hazards involved with operation and use of the machine. Using the machine with respect and caution will considerably lessen the possibility of personal injury. However, if normal safety precautions are overlooked or ignored, personal injury to the operator may result. This machine was designed for certain applications only. We strongly recommends that this machine NOT be modified and/or used for any application other than for which it was designed. If you have any questions relative to its application DO NOT use the machine until you contact with us and we have advised you.

Read all the following instructions before attempting to operate this product and save these instructions!

1. Keep work area clear
 - Cluttered areas and benches invite injuries.
2. Consider work area environment
 - Do not expose tools to rain.
 - Do not use tools in damp or wet locations.
 - Keep work area well lit.
 - Do not use tools in the presence of flammable liquids or gases.
3. Guard against electric shock
 - Avoid body contact with earthed or grounded surfaces.
4. Keep other persons away
 - Do not let persons, especially children, not involved in the work touch the tool or the extension cord and keep them away from the work area.
5. Store idle tools
 - When not in use, tools should be stored in a dry locked-up place, out of reach of children.
6. Do not force the tool
 - It will do the job better and safer at the rate for which it was intended.
7. Use the right tool
 - Do not force small tools to do the job of a heavy duty tool.
 - Do not use tools for purposes not intended; for example do not use circular saws to cut tree limbs or logs.
8. Dress properly
 - Do not wear loose clothing or jewellery, they can be caught in moving parts.
 - Non-skid footwear is recommended when working outdoors.
 - Wear protective hair covering to contain long hair.
9. Use protective equipment
 - Use safety glasses.
 - Use face or dust mask if cutting operations create dust.
10. Connect dust extraction equipment
 - If device are provided for the connection of dust extraction and collecting equipment, ensure these are connected and properly used.
11. Do not abuse the cord
 - Never yank the cord to disconnect it from the socket. Keep the cord away from heat, oil and sharp edges.
12. Secure work
 - Where possible use clamps or a vice to hold the work. It is safer than using your hand.
13. Do not overreach
 - Keep proper footing and balance at all times.
14. Maintain tools with care
 - Keep cutting tools sharp and dean for better and safer performance.
 - Follow instructions for lubricating and changing accessories.
 - Inspect tool cords periodically and if damaged have them repaired by an authorized service facility.
 - Inspect extension cords periodically and replace if damaged.
 - Keep handles dry dean and free from oil and grease.
15. Disconnect tools
 - When not in use, before servicing and when changing accessories such as blades, bits and cutters disconnect tools from the power supply.
16. Remove adjusting keys and wrenches
 - Form the habit of checking to see that keys and adjusting wrenches are removed from the tool before turning it on.
17. Avoid unintentional starting
 - Ensure switch is in "off " position when plugging in.
18. Use outdoor extension leads
 - When the tool is used outdoors, use only extension cords intended for outdoor use and so marked.
19. Stay alert
 - Watch what you are doing, use common sense and do not operate the tool when you are tired.
20. Check damaged parts
 - Before further use of tool, it should be carefully checked to determine that it will operate properly and perform its intended function.
 - Check for alignment of moving parts, binding of moving parts, breakage of parts, mounting and any other conditions that may affect its operation.
 - A guard or other part that is damaged should be properly repaired or replaced by an authorized service centre unless otherwise indicated in this instruction manual.
 - Have defective switches replaced by an authorized service centre.
 - Do not use the tool if the switch does no turn it on - and off.
21. Warning
 - The use of any accessory or attachment other than one recommended in this instruction manual may present a risk of personal injury.
22. Have your tool repaired by a qualified person
 - This electric tool complies with the relevant safety rules. Repairs should only be carried out by qualified persons using original spare parts, otherwise this may result in considerable danger to the user.

SPECIFICATIONS

EB-260A

Capacity	(mm)	90°	● 225 ■ 225 x 180
		60°	● 100 ■ 100 x 100
		45°	● 150 ■ 140 x 140
Speeds	(MPM)	45 / 90	
Motors	Saw	<i>Customed</i>	
		240V, 50HZ, 1Phase	
Motors	Coolant	50W	
		240V, 50HZ, 1Phase	
Blade	(mm)	27 x 0.9 x 2480	
Blade Wheels	(mm)	292 (<i>High strength flanged cast iron</i>)	
Dimensions	(mm)	Length	1500
		Width	510
		Height	935 (<i>Cutting area</i>)
		Height	1570 (<i>Total</i>)
Packing		1380 x 580 x 930	
Weight	(kg)	200 / 216	
Miter Scale		0 ~ 60°	
Noise	(dB)	70 (<i>Weighted sound pressure level</i>)	
Fuse		max. 16A	

ATTENTION!

Because there is no built in fuse in this saw, the saw has to be fused by the fuse of the building installation. The maximum value of the building installation fuse has to be 16A.

FEATURES

1. Special designed horizontal band saw.
2. Offers two speeds for cutting metal.
3. With cooling pump for prolongation of the saw blade life.
4. With triggering knob at the handle for easy and safe use.
5. With scale for the mitering vise and graduation.
6. Stand for safe use.

DELIVERY

1. Transportation to desired location before unpacking, please use lifting jack.
2. Unpack all the parts.
3. Transportation after unpacking, please use heavy duty fiber belt to lift up the machine.
Always keep proper footing and balance while moving this machine.
As this machine weights 157kgs it is recommended that the machine be transported with help of lifting jack.

INSTALLATION

1. Position the base of the machine on a solid cement floor and then fix it to the ground.
2. Put the bandsaw at the base and fasten it with the delivered screws.
3. Secure the cutting head by the safety lever.
4. Assemble the roller holding arm.
5. Tighten all locks before operation.
6. Check carefully if the sawblade is running in counter-clockwise direction. If not, exchange two wires at the plug. Then repeat the running test.
7. Make sure that the blade is not impeded in any way.
8. Position the adjustable blade guide to its most left position. Turn the blade tension handwheel to tighten the blade. Correct tension will be reached, if the sawblade can be pushed for 3 mm in the middle of the cutting area with a force of 50 N.
Please note! Incline the handle of the blade tension handwheel in such manner, that hitting of the handwheel of the vice is impossible.
9. Fill the tank with coolant liquid by using a mixture of water and oil in the 7-10% percentage.
10. Check that the mains voltage corresponds to that reported on the motor.

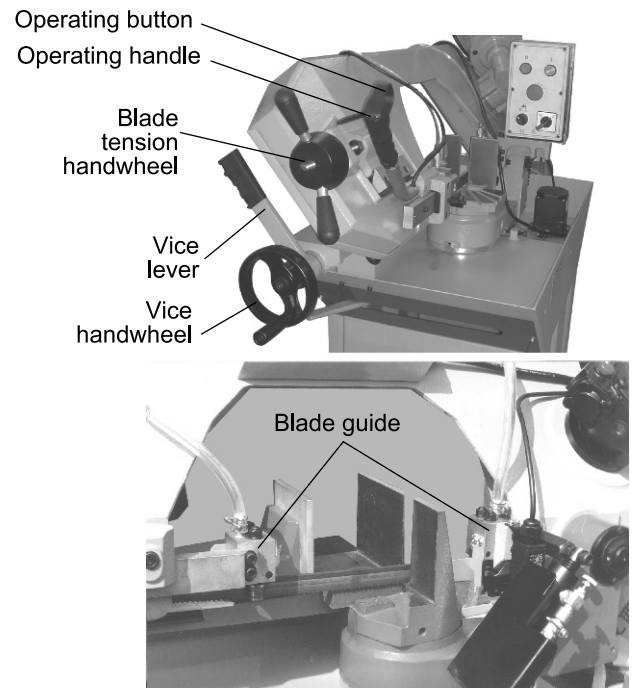

WORKING WITH THIS MACHINE

1. Position the vice about 4 mm from the workpiece by operating the vice handwheel.
2. Clamp the workpiece in the vice completely by turning the vice lever.
3. Position the adjustable blade guide head as near as possible to the workpiece.
4. Operate the speed switch by selecting the appropriate speed:
 - in the 1st pos. the cutting speed is 40 m/min(CY210), 45 m/min(CY275).
 - in the 2nd pos. the cutting speed is 80 m/min(CY210), 90 m/min(CY275).
5. Connect the cable to the mains according to the accident-prevention standards.

ATTENTION: GROUND WIRE.

6. Choose, if you would like to use coolant or not. For pumping coolant, please turn the switch with the inscription coolant to the "I"-position, If you do not wish to use coolant, turn this switch to the "O"-position.

ATTENTION:

Before start the machine, make sure, that blade is suitable to workpiece specifications. Make also sure that all protective covers are installed and tighten correctly by screws.

7. Unsecure the cutting head.
8. After that, lead down the cutting head to about 5 mm to the workpiece, press the operating button of the handle to start the rotation of the blade and to start the cooling system.
9. There are two different control systems of this saw:
 - CY210/275: The push button at the handle is a trigger button. That means, the saw is working, as long as the button is pushed. If the push button is released, the saw and the coolant will stop.
 - CY210A/275A: The push button at the handle start the saw and the coolant. Both will be stopped, if the cut is done and the limit switch was pressed automatically. In case that anything will happen and the saw has to be stopped before the cut is completed, press the Emergency Stop button.
10. If the sawblade has reached its full speed, you can push down the saw bow.

Please be careful! Feed the bow slowly and with normal force. High force will damage the sawblade and the saw. (At the type CY210a the downfeed can be adjusted at the screw of the hydraulic downfeed unit.)

11. In case of any emergency, press the red palm-EMG-button at the control box. The saw will stop immediately. To release the EMG-switch, please turn the palm-button and release it.

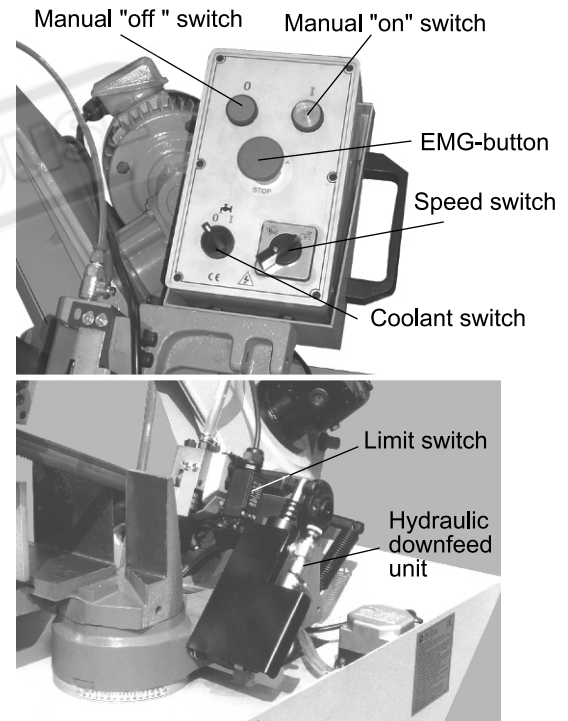

INCLINED CUTS

If you wish to make inclined cuts, release the lever and turn the bow according to the desired angle and clamp the lever again.

REPLACEMENT OF THE BLADE

ATTENTION!

Before doing any maintenance or servicing switch off and unplug the machine.

1. Lift the bow completely.
 2. Secure the cutting head (by safety lever)
 3. Loosen the blade tension handwheel and remove the blade protection.
 4. Replace the blade by inserting it first between the bearings of the blade guide heads and then by positioning it on the housings of the flywheels.
- ATTENTION: Check the cutting direction of the blade teeth. It has to be according to the arrow at the bow. Tighten the blade again.

Blade tension: The correct blade tension is reached, if the sawblade can be pushed for **3** min the middle of the cutting area with a force of **50 N**. For this adjustment, the adjustable blade guide has to be at its most left position.

Please note! Incline the handle of the blade tension handwheel in such manner, that hitting of the handwheel of the vice is impossible.

Be careful! After any dismantling of the blade protection, be sure, that this cover is replaced and secured by the screws again. Do never manipulate the safety switch. Accidents may happen if this is disregarded.

MAINTENANCE

Attention! In each case before you will do any maintenance switch off the machine and unplug it. Secure the cutting head by the safety lever!

1. Lubricate the slide, the vice, and the blade guide periodically. Clean the coolant tank from the chips.
2. The reduction gear has already been lubricated with synthetic grease and, therefore, it does not require any maintenance.

IMPORTANT: At the end of each working day, it is necessary to loosen blade tension, unplug the machine and secure the cutting head (by safety lever)!

Remember to put the blade under tension again when you resume your work.

ADJUSTMENT OF BLADE GUIDE BEARINGS

1. Unloose the nut and unscrew the dowel (ref.No.80), by increasing the gap between the blade and the bearings.
2. Then adjust the upper bearing; If necessary, unloose the screws on the arm (ref.No.74).
3. In order to adjust the pair of side bearings (ref.No.78), act on the dowel (ref.No.80) so that the bearings rest on the blade and, then, loose it as much as it is necessary to let the blade slide, by leaving a backlash of about 0.04 mm.
4. When the adjustment has been completed, tighten its nut.

ATTENTION:

Please make sure to always assemble 0.9 mm thick blades for which the bearings of the blade guide have been adjusted. In case of thicker blades, if is necessary to adjust the blade guide once again as above mentioned.

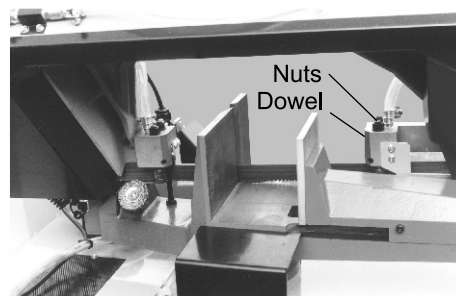
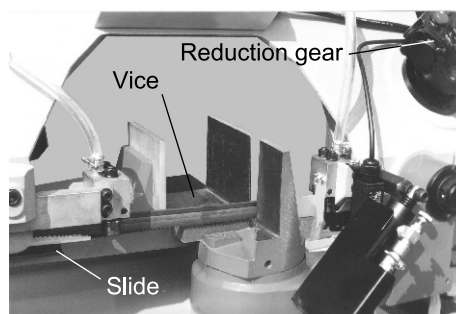
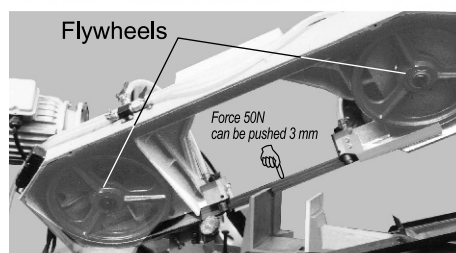
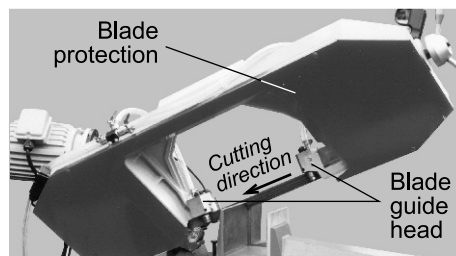
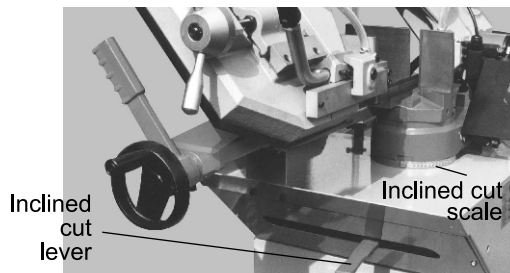

EXPLODED VIEW EB-260A

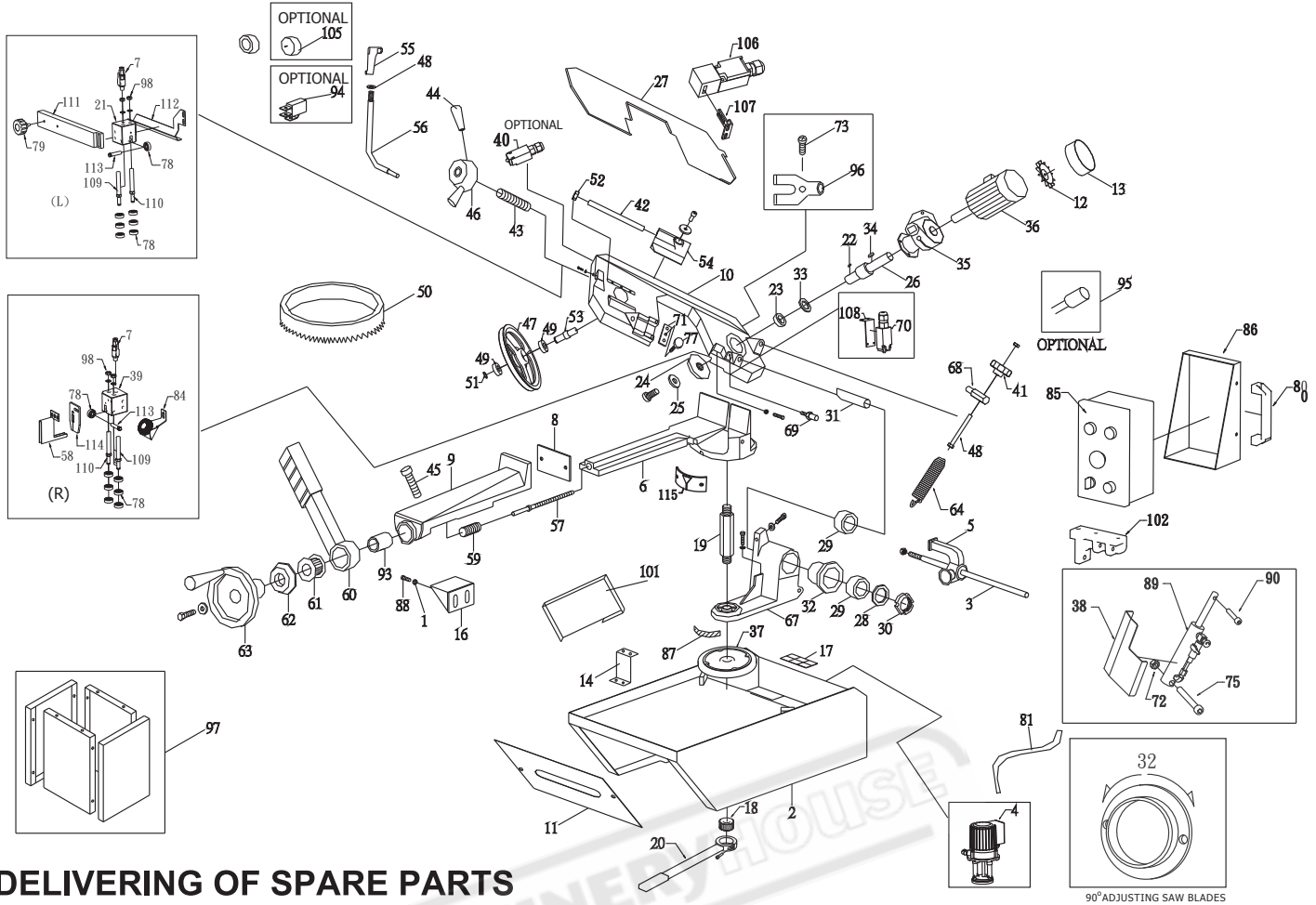

DELIVERING OF SPARE PARTS

Please note: When ordering spare parts please always mention: Model of the machine, Serial number and Reference number of the part
SHOULD REF. NUMBERS MISSING, NO SPARE PART WILL BE DELIVERED.

LIST OF SPARE PARTS

Ref. No.	Description	Ref. No.	Description	Ref. No.	Description	Ref. No.	Description
01	Washer 華司	31	Pivot 支架軸	60	Vice lever 虎鉗柄	91	Fixed blade guide plate 培林座
02	Base 底座	32	Bearing cover 偏心套	61	Bearing 培林	92	Mobile blade guide plate 大培林座
03	Bar stop rod 長度桿	33	Washer 華司	62	Bearing cover 培林蓋	93	Bush 虎鉗套管
04	Cool pump 冷卻馬達	34	Key 8 x 7 x 25 mm 鍵	63	Vice handwheel 手輪	94	(手切)Toger switch 微動開關
05	Bar stop 長度板	35	Reducer 齒輪箱	64	Spring 彈簧	95	Condenser(Motor) 電容器
06	Countervice 虎鉗下座	36	Motor 馬達	65	Spring connection 拉鉤	(optional)	
07	Valve 水開關	37	round table 圓座	66	Revolving arm 旋轉座	96	Coolant distributor 水分頭
08	Vice jaw 前檔板	38	Plate(optional) 油壓護蓋	67	Hex. nuts 螺帽	97	Stand 腳架
09	Vice 虎鉗上座	39	Mobile blade guide plate 大培林座	68	Spring 彈簧	98	Nut M10 螺帽
10	Body frame 鋸弓	40	Switch(optional) 開關	69	Stop bolt 固定軸	99	Pivots centric 培林軸正心
11	Casing 底座蓋	41	hand wheel 調整柱	70	Micro switch(optional) 微動	101	Plate 水盤
12	Motor Fan 馬達扇葉	42	Threaded shaft 拉塊桿	71	Block 固定板	102	Bracket 支架
13	Motor Cover 馬達蓋	43	Spring washer 彈簧片	72	Hex. nuts 螺帽	104	Pivots excetric 培林軸偏心
14	Connection Plate 連接板	44	Grip 調整柱柄	73	Rubber connection 冷卻螺絲	105	Blade Tension Gauge 壓力錶
15	Arm 頂料板	45	Pin 調整螺絲	74	Arm 長支架	(optional)	
16	Filter 網	46	Handwheel 調整柱	75	Bolt 螺柱	106	Switch 微動開關
17	Bush 旋轉螺帽	47	Return flywheel 上鋸輪	76	Blade guard 長保護片	107	Key 鑰匙
18	Pin 旋轉軸	48	Hex. Nut 螺帽	77	Handle 任意把手	108	block 微動固定板
19	Lever 旋轉柄 長把手	49	Bearings 2Z/6205 6205 培林	78	Bearing 6082Z 608 培林	109	Pivots centric 培林軸正心
20	Fixed blade guide plate 培林座	50	Saw blade 鋸片	79	Hand wheel 枝架柱頭	110	Pivots excetric 培林軸偏心
21	Key 7x7x35mm 鍵	51	C-ring C 型扣	80	Handle 旋轉手柄	111	ARM 長支架
22	Bearing 培林	52	Hex. nuts. 螺帽	81	Water Pipe 水管	112	Blade guard 長保護片
23	Motor flywheel 下鋸輪	53	Block blade tension 滑座	82	Rust Plate 擋屑板	113	PIN 培林座擋削
24	Washer 蓋	54	Block blade tension 滑座	83	L. Bladeguard 保護片	114	Rust Plate 擋屑板
25	Shaft 鋸輪主軸	55	Handle 手柄	84	Steel wire 鋼絲輪組	115	Scale 指針
26	Blade cover 鋸弓護蓋	56	Lever 手柄桿	85	Switch(optional) 開關		
27	Ring nilons 培林蓋	57	Vice screw 角牙桿	86	Switch Shelf 開關架		
28	Bearing 32006 培林	58	R. Bladeguard 刀型保護片 右	87	Scale 表尺		
29	Ring nut M30 主軸帽	59	Vice spring 彈簧	88	Cylinder(optional) 油壓缸		
				89	Pin(optional) 油壓缸螺絲		

TO REMOVE CUTTING TROUBLE:

1. When the saw blade cutting can't become 90°, for example pic. A

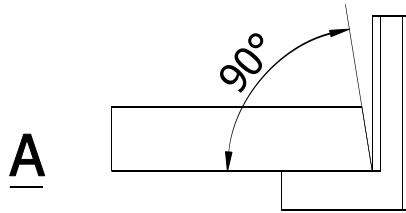

2. Replace the saw blade to try to cut again for example pic. B

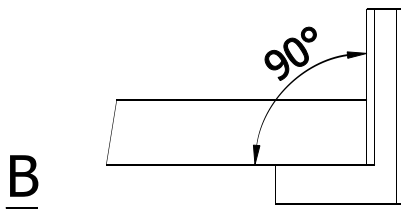

3. Inspect the blade guide plate and saw blades, ensure they are 90°, pic. D1, D2, D3

saw bow upward

saw bow downward

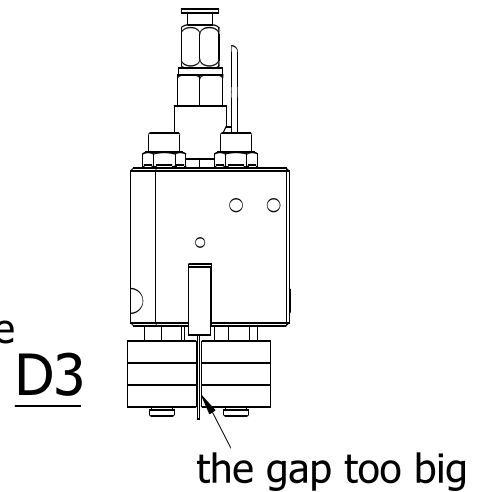
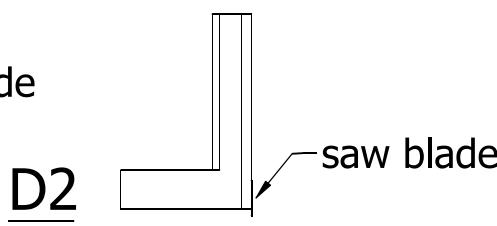
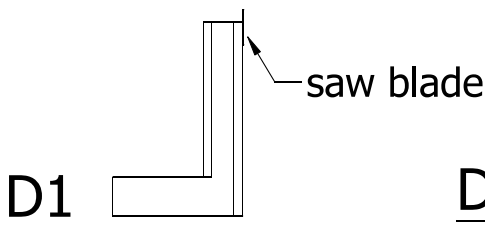

4. If they are not 90°, pls adjust 32 # the saw blade to become 90°, pic. c

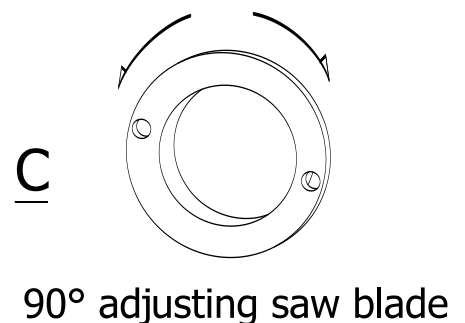

ELECTRICAL CIRCUIT DIAGRAM EB-260A

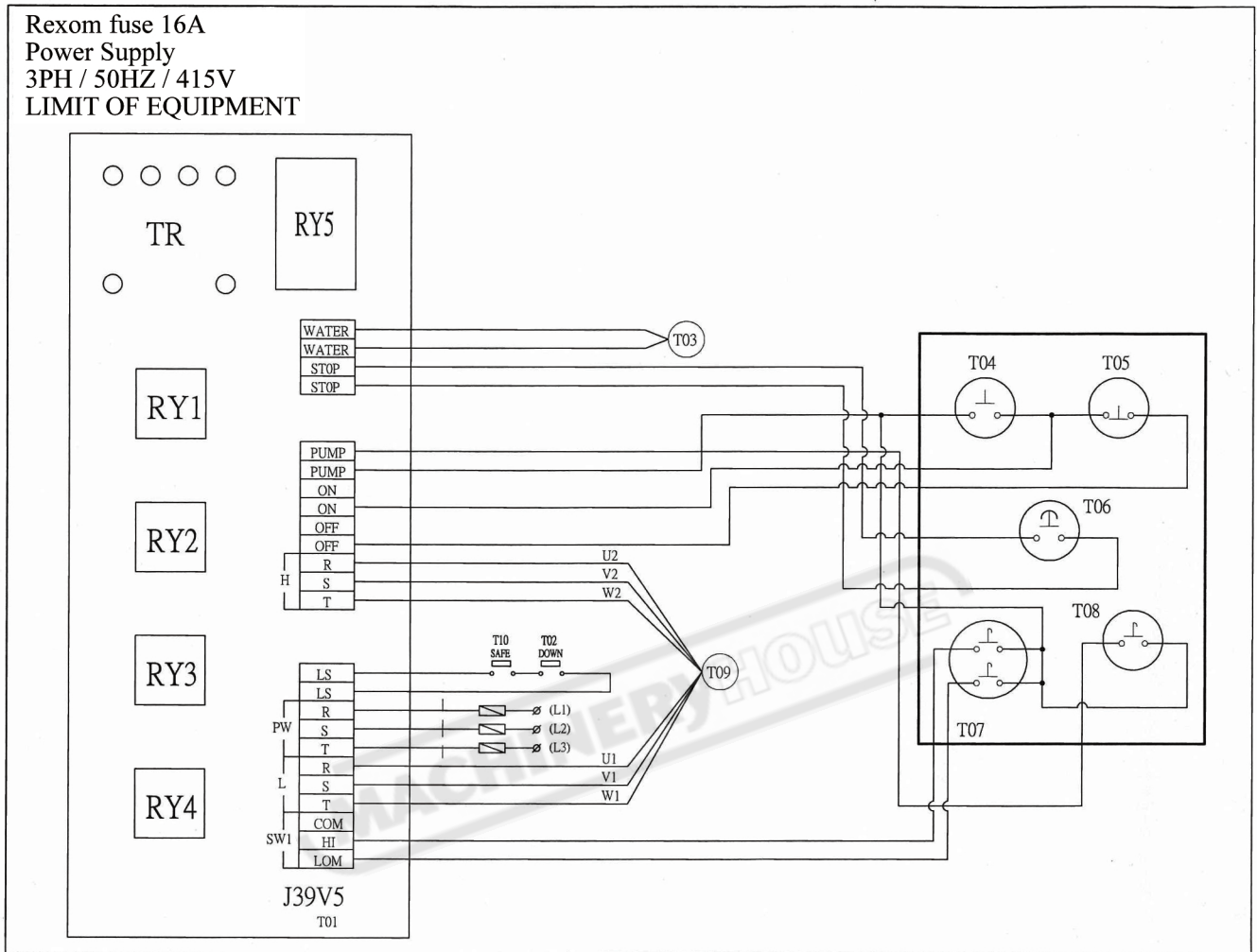

Electrical parts list

Part No	Name	Dscription	Producer	Mark
T01	PCB	J39V5	GEORGE	CE
T02	DOWN MICRO	MICRO SWITCH	HAILY	CE
T03	M2	PUMP MOTOR	GEORGE	CE
T04	ON	I SWITCH	TEND	CE
T05	OFF	O SWITCH	TEND	CE
T06	EMS	EMERGENCY STOP	DEMEX	CE
T07	SPEED	SPEED SWITCH	TEND	CE
T08	COOL	PUMP SWITCH	TEND	CE
T09	M1	SAW MOTOR	GEORGE	CE
T10	SAFE	SAFE MICRO	HAILY	CE